

SimplyRhino

sales, training and support

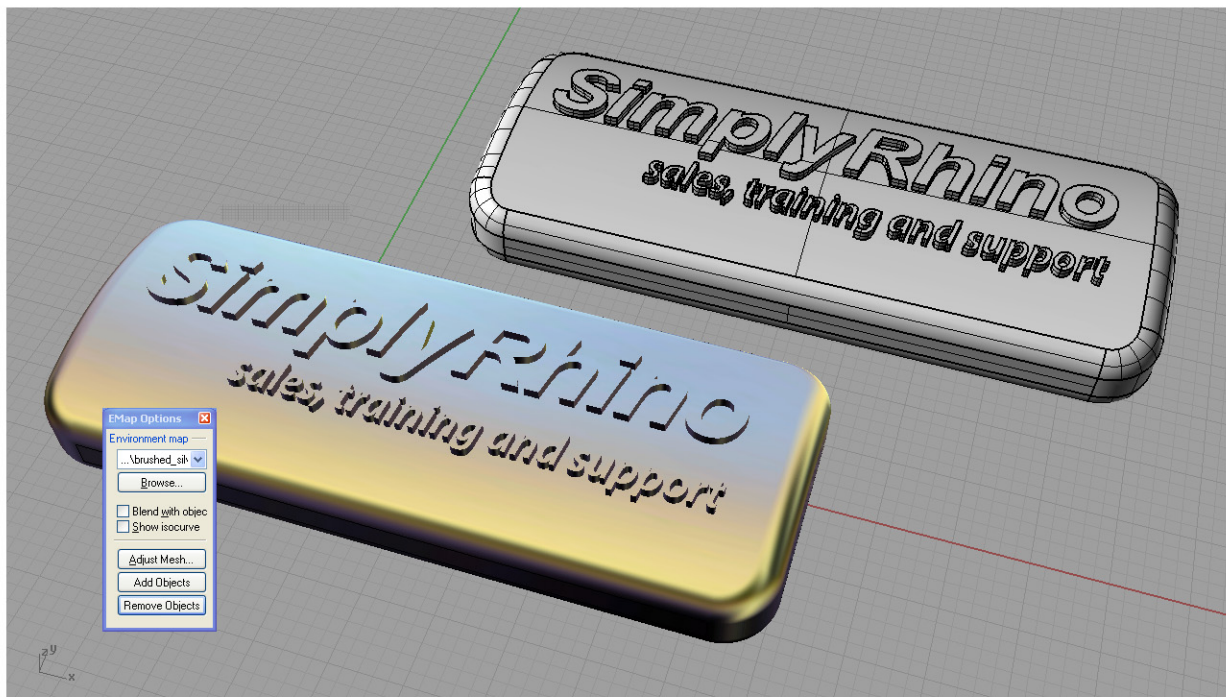

Level 1 Training Outline & Objectives

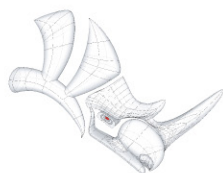

Rhinoceros[®]
NURBS modeling for Windows

Simply Rhino Limited
0208 498 9900
www.simplyrhino.co.uk
training@simplyrhino.co.uk

Level 1 – NURBS modelling with Rhino

Course Outline

This course is for anyone new, or nearly new, to Rhino 4. Recognised as THE introductory course for Rhino 4, all trainees receive an Official Certificate on completion and all courses are delivered by the most experienced Rhino trainers in the U.K.

Each trainee receives the official 260 page courseware as part of attending this course.

Whatever your market, if you want to get off to the best possible start, develop a good understanding of best practice approaches to modelling in Rhino 4, this is the course for you.

Simply Rhino Limited have successfully taken hundreds of trainees through this course from Jewellers to Architects, Product Designers to Marine Designers, this is the ONLY introductory class for you.

In this comprehensive 2-day class you'll learn to create and edit accurate free-form 3-D NURBS models. This fast-moving class covers most of Rhino's functionality, including the most advanced surfacing commands

Structure

In this class, you will systematically move through the user interface, command access, creation and editing of curves, surfaces and solids. Information will be presented at an accelerated pace.

Expected Outcomes

After this course the student is expected to be able to:

- Move comfortably around the Rhino modelling window.
- Identify when free form or precision modelling is required.
- Create and edit curves, surfaces, and solids.
- Use modelling aids for accuracy.
- Produce simple renderings of the Rhino models.

Target Audience

This course is for the design professional who wants to efficiently learn the concepts and features of the Rhinoceros modelling software at an accelerated pace in an instructor-led environment.

Prerequisites

Requires Windows skills and desire to model. Previous drafting and modelling experience helpful but not required. If trainees have attempted to work through tutorials on either evaluation, student or commercial version of Rhino 4, this will help. If you would like an evaluation version please contact us at Simply Rhino Limited.

Curriculum

Day 1

After a brief introduction, the following concepts will be covered:

- Get acquainted with the Rhino screen and menus
- Navigate around the Rhino model
- Create 2-D lines, polylines, and NURBS curves
- Modelling set-up and mode functions: snap, ortho and planar constraints
- Object snaps and Smart Track
- Fast 3-D solids and surfaces
- The Rhino layering system

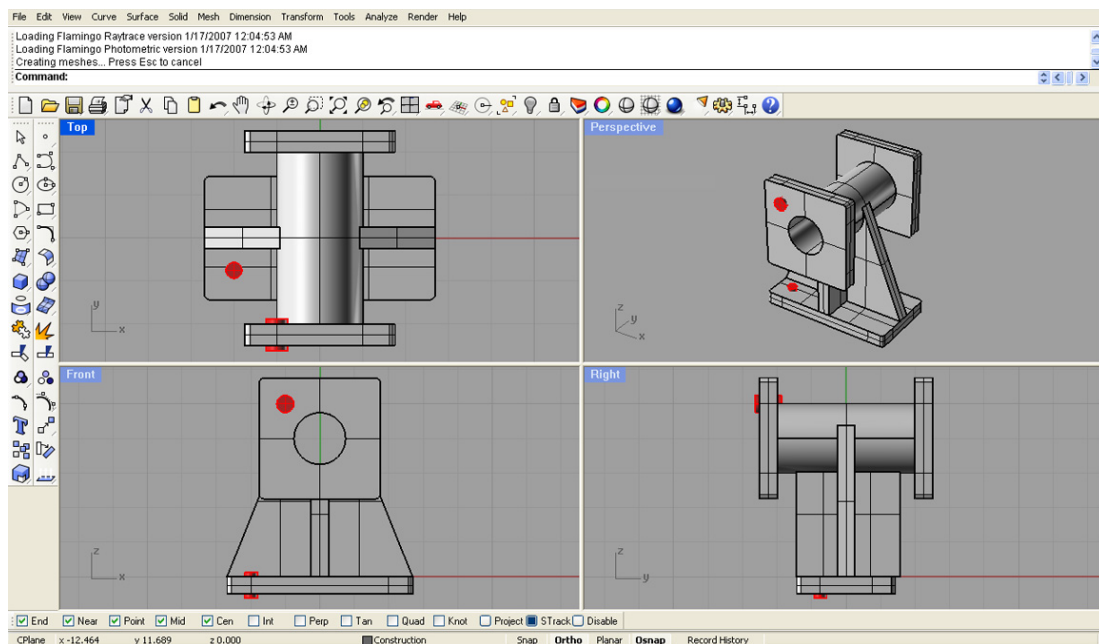

Precision Modelling

Use co-ordinates and constraints to model easily and accurately. Move off the x-y plane and use viewports to establish the current construction plane. Draw polygons and ellipses. Draw free-form curves and compare interpolated and control points curve.

- Draw with absolute, relative rectangular, and polar co-ordinates
- Distance and angle constraints
- Viewports and construction planes
- Model in 3-D space
- Elevator mode
- Rectangle command and its options
- Point selection with object snaps
- Analysis commands: length, distance, angle, radius
- Draw circles and arcs
- Draw ellipses and polygon curves
- Rhino render and render colour
- Model free-form curves
- Create helix and spiral curves

Followed by more on Curves, Display, and Editing

Discover display commands used to view different parts of the model. Use edit commands to produce complex and detailed variations on the curves. Loft and extrude curves into surfaces and solids.

- Pan, zoom and reset model views
- OpenGL shade
- Edit curves with fillet and chamfer
- Loft and extrude curves
- History
- General editing: move, copy, rotate, mirror, scale
- Array polar and rectangular
- Boolean union, difference, and intersection
- Offset curves and surfaces
- Trim and split for curves and surfaces
- Extend and extend to surface

Day 2

Intermediate Edit and Surfacing Commands

Learn additional editing commands and use them to build practice models. Reinforce concepts of model set-up and drawing accurate 2-D geometry to build precision 3-D shapes

- Introduction to NURBS modelling concepts and terminology
- Free-form curves
- Control point editing of curves and surfaces
- Rebuild curves and surfaces
- Use the nudge modelling aid
- Create deformable shapes
- Curve creation through projection
- Split surfaces with curves and surfaces
- Blend between two surfaces
- Symmetry Tool
- Lighting and rendering
- Make 2D drawings from 3D Objects
- Page Layouts

Advanced Surfacing and Solids

Model with solids and solid text. Use Boolean tools to shape your model. Extrude, loft, and revolve curves into surfaces. Use sweeps to create additional surfaces. Use advanced surfacing techniques like blend, match, and surface from network of curves.

- Create model primitives and solid text
- Model with pipe and extrude
- Modifying solids with Boolean Tools
- More surfaces
- Extrude and loft surfaces
- Revolve curves into surfaces
- Sweep 1 and 2 rail curves
- Surface with network of curves

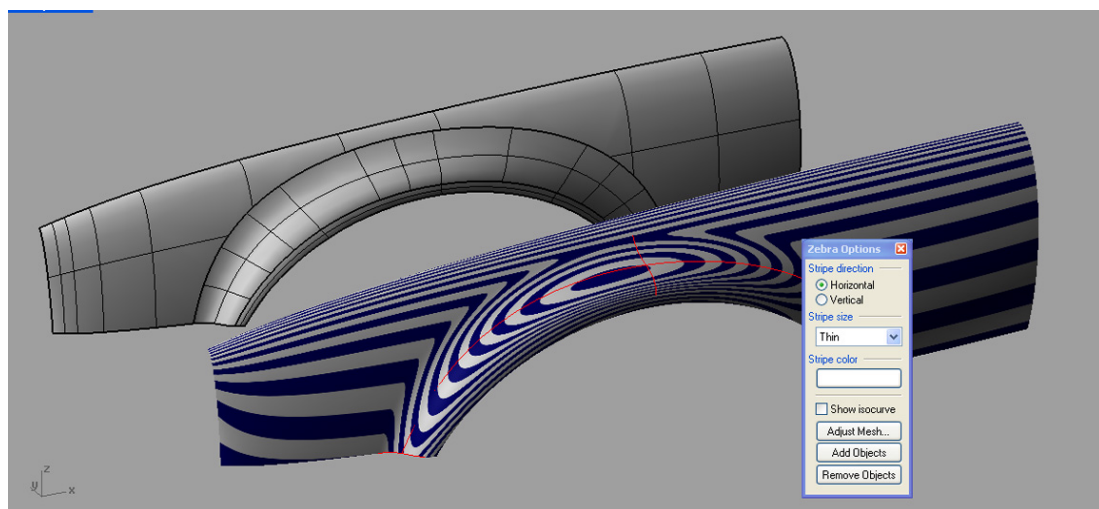

Let's Model

Originally, this course was designed to be delivered over a three day format, Simply Rhino have since found that it is possible to deliver all key lessons in a condensed two day session. The format for the last part of day 2 allows trainees to focus on the lessons that most interest them, here are some possible subjects:

Reinforce the commands and skills gained in the class by creating several models including the hammer and the bottle. Add texture, bump and materials to the Rhino model for rendering. Annotate the Rhino model by adding dimensions. Work with the Options dialog box to refine the Rhino modelling environment. Generate 2-D views of a model for detailing and exporting. Also output wire-frame images directly to printers and plotters from Rhino.

Time permitting: Customise Rhino toolbars and workspaces. Use the Flamingo plug-in to render a model and compare the finished rendering with Rhino's renderer.

- Set-up the hammer model
- Create the hammer construction lines with precision
- Build the hammer surfaces
- Render the hammer
- Set-up the bottle model
- Create the syrup bottle construction lines with precision
- Build the bottle surfaces
- Add the threads
- Render the bottle
- Import and export models
- Generate 2-D drawings from 3-D model and export
- Print wire-frame views of the model
- Edit and create new toolbars and tool buttons for rhino

© Simply Rhino Limited 2007